

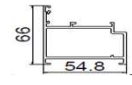

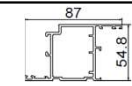

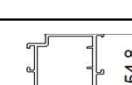



## BẢNG BÁO GIÁ

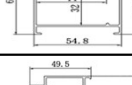

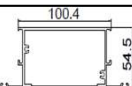
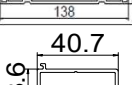
TP.HCM ngày 10 tháng 03 năm 2021

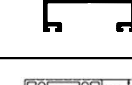
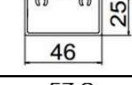
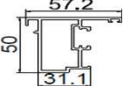
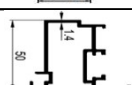
STT	MÃ HÀNG	TÊN GỌI	MẶT CẮT	ĐỘ DÀY	CHIỀU DÀI	(Kg/M)	ĐƠN GIÁ/KG	THÀNH TIỀN
<b>CỬA ĐI XINGFA HỆ 55</b>								
1	C3328	Khung bao cửa đi hệ 55		2	5.8	1.257	97,000	707,188
2	C3332	Cánh cửa đi mở trong hệ 55		2	5.8	1.442	97,000	811,269
3	C3303	Cánh cửa đi mở ngoài hệ 55		2	5.8	1.441	97,000	810,707
4	C44508	Khung bao cửa đi hệ 55 dày 1.4ly		1.4	5.8	0.927	97,000	521,530
5	C44512	Cánh cửa đi mở ngoài hệ 55 dày 1.4ly		1.4	5.8	1.132	97,000	636,863
6	C44522	Cánh cửa đi mở trong hệ 55 dày 1.4ly		1.4	5.8	1.132	97,000	636,863
7	C3304	Cánh cửa đi ngang dưới hệ 55		2	5.8	2.023	97,000	1,138,140
8	C3329	Nẹp gioăng lọc bụi cho cửa đi ngang dưới hệ 55		1.5	5.8	0.428	97,000	240,793
9	C22900	Nẹp gioăng lọc bụi cho cửa đi ngang dưới hệ 55 có gờ		1.5	5.8	0.476	97,000	267,798
10	C3319	Ngưỡng cửa , cửa đi hệ 55		1.6	5.8	0.689	97,000	387,631
11	C3323	Đồ động cửa đi 2 cánh hệ 55		1.8	5.8	1.086	97,000	610,984
12	C22903	Đồ động cửa đi/ Sổ 2 cánh hệ 55		1.4	5.8	0.891	97,000	501,277
13	C3310	Nối khung cho vách kính lớn hệ 55		1.6	5.8	1.308	97,000	735,881
14	C3300	Nối khung cho vách kính, cửa hệ 55		2	5.8	0.347	97,000	195,222

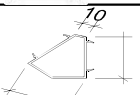

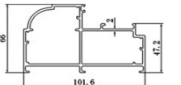
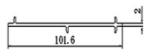
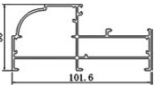
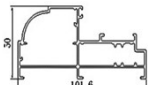

15	C3209	Khung bao cho vách kính		1.4	5.8	0.802	97,000	451,205
16	C459	Thanh truyền khóa cửa đi , cửa sổ hệ 55		2.5	5.8	0.139	97,000	78,201
17	C3326	Nối khung 90 độ hệ 55		2.2	5.8	1.275	97,000	717,315
18	F077	Pano có rãnh cửa đi hệ 55		1	5.8	0.664	99,000	381,269
19	C3297	Nẹp kính vuông cho kính 5-10mm hệ 55		1	5.8	0.271	97,000	152,465
20	C3206	Nẹp kính bầu cho kính 5 -10 mm hệ 55		1	5.8	0.257	97,000	144,588
21	C3236	Nẹp kính hộp cho kính 16 - 19 mm hệ 55		1	5.8	0.227	97,000	127,710
<b>CỬA SỔ XINGFA HỆ 55 DÀY</b>								
22	C3209	Khung bao cho vách kính		1.4	5.8	0.802	97,000	451,205
23	C3318	Khung bao cửa sổ hệ 55		1.4	5.8	0.876	97,000	492,838
24	C3208	Khung bao chuyển hướng		1.4	5.8	0.76	97,000	427,576
25	C3202	Cánh cửa sổ mở quay ngoài		1.4	5.8	1.088	97,000	612,109
26	C8092	Cánh cửa sổ mở quay ngoài ke nháy		1.4	5.8	1.064	97,000	598,606
27	C3033	Đồ động cửa sổ mở quay 2 cánh		1.4	5.8	0.825	97,000	464,145
28	C3313	Đồ cố định chữ T tách khung		1.4	5.8	1.01	97,000	568,226
29	C3203	Đồ cố định chữ T có lỗ vít		1.4	5.8	0.97	97,000	545,722
30	C459	Thanh truyền khóa cửa đi , cửa sổ hệ 55		2.5	5.8	0.139	97,000	78,201
31	C3297	Nẹp kính vuông cho kính 5-10mm hệ 55		1	5.8	0.271	97,000	152,465
32	C3298	Nẹp kính cho C3328, C3318, C3313 kính 5-10mm hệ 55		1	5.8	0.237	97,000	133,336
33	C3206	Nẹp kính bầu cho kính 5 -10 mm hệ 55		1	5.8	0.275	97,000	154,715

34	C3236	Nẹp kính hộp cho kính 16 - 19 mm hệ 55		1	5.8	0.227	97,000	127,710
35	C3336	Nẹp kính hộp cho kính 8-10 mm hệ 55		1	5.8	0.229	97,000	128,835
36	C910	Nối góc 135		1.8	5.8	0.916	97,000	515,342

### CỬA MỞ QUAY HỆ 55 BẮN 100

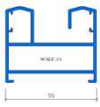
37	C38019	Khung bao cửa đi mở quay hệ 100		2	5.8	2.057	98,000	1,169,199
38	C38010	Thanh ghép khung hệ mở quay 100		2	5.8	0.617	98,000	350,703
39	C38039	Khung bao vách kính hệ 100		1.4	5.8	1.375	98,000	781,550
40	C38038	Khung bao cửa sổ mở quay hệ 100		1.4	5.8	1.421	98,000	807,696
41	C38032	Thanh ngang dưới cửa đi mở quay hệ 55		2	5.8	2.26	97,000	1,271,476

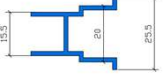
### CỬA LÙA ĐI 55

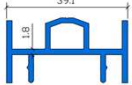
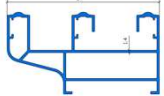
42	D47713	Khung bao lùa đi 55		1.8	5.8	1.223	98,000	695,153
43	D45316	Cánh lùa đi hệ 55		1.8	5.8	1.319	98,000	749,720
44	D46070	Ốp khóa trung gian cửa đi lùa		1.5	5.8	0.364	98,000	206,898
45	D45478	Ốp cánh cửa đi lùa 55		1.4	5.8	0.383	98,000	217,697
46	D45318	Trung gian cửa đi lùa 55		1.8	5.8	0.566	98,000	321,714
47	D45482	Khung cửa sổ lùa 3 ray hệ 55		1.4	5.8	1.467	98,000	833,843



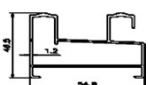

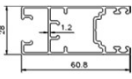
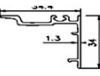
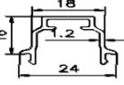
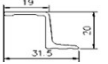



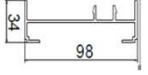
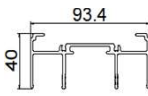
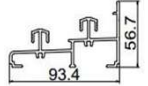
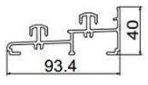
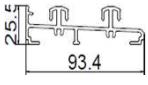
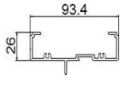
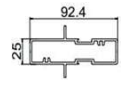
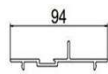
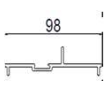
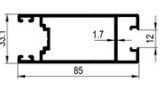
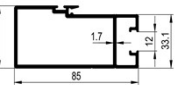

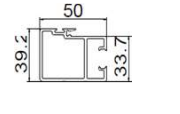
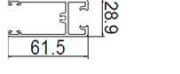
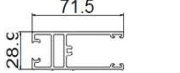

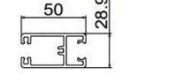
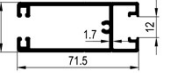
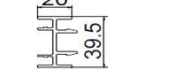
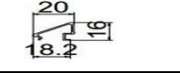
### XINGFA HỆ LÙA 55

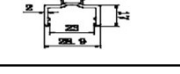
48	D23151	Khung bao cửa lùa hệ 55		1.4	5.8	0.949	97,000	533,907
----	--------	-------------------------	---	-----	-----	-------	--------	---------



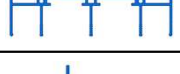

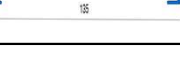

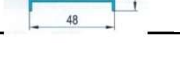
49	<b>D23156</b>	Cánh cửa lùa hệ 55		1.4	5.8	0.936	<b>97,000</b>	<b>526,594</b>
50	<b>D23157</b>	Ốp góc cho cánh cửa lùa hệ 55		1.4	5.8	0.365	<b>97,000</b>	<b>205,349</b>
51	<b>D23158</b>	Trung gian 4 cánh cửa lùa hệ 55		1.4	5.8	0.229	<b>97,000</b>	<b>128,835</b>
52	<b>D23159</b>	Thanh chắn nước mưa cửa lùa 55		1.4	5.8	0.279	<b>97,000</b>	<b>156,965</b>

**CỬA ĐI MỞ TRƯỢT XINGFA HỆ 2001/93**

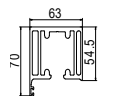
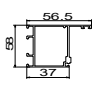
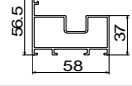
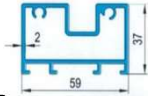
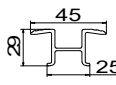
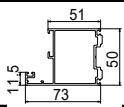
53	D1543A	Khung bao đứng cửa đi lùa 2001		1.8	5.8	1.134	<b>97,000</b>	<b>637,988</b>
54	D1541A	Khung bao ngang trên cửa đi lùa 2001		1.8	5.8	1.459	<b>97,000</b>	<b>820,833</b>
54	D1542A	Khung bao ngang dưới cửa đi lùa 2001 cao 57mm		1.8	5.8	1.706	<b>97,000</b>	<b>959,796</b>
55	D1942	Khung bao ngang dưới cửa đi lùa 2001 cao 40mm		2	5.8	1.561	<b>97,000</b>	<b>878,219</b>
55	D17182	Khung bao ngang dưới cửa đi lùa 2001 cao 25mm		2	5.8	1.307	<b>97,000</b>	<b>735,318</b>
56	D1559A	Khung bao ngang cho vách kính cửa đi lùa 2001		1.7	5.8	1.07	<b>97,000</b>	<b>601,982</b>
56	D2618	Đồ trung gian cho vách kính cửa đi lùa 2001		2	5.8	1.546	<b>97,000</b>	<b>869,780</b>
57	D1578	Nối khung cho vách kính cửa đi lùa 2001		2	5.8	0.676	<b>97,000</b>	<b>380,318</b>
57	D1549A	Nối khung bao cho vách kính cửa đi lùa 2001		1.7	5.8	0.712	<b>97,000</b>	<b>400,571</b>
58	D1546A	Cánh đứng bên cửa đi lùa 2001		1.7	5.8	1.273	<b>97,000</b>	<b>716,190</b>
58	D26146	Cánh đứng bên cửa đi lùa 85mm		2	5.8	1.33	<b>97,000</b>	<b>748,258</b>
59	D28127	Cánh đứng góc cửa đi lùa 85mm		2	5.8	1.303	<b>97,000</b>	<b>733,068</b>

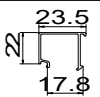
59	D1547A	Cánh đứng móc cửa đi lùa 2001		1.7	5.8	1.098	97,000	617,735
60	D1545A	Cánh ngang dưới bên trong cửa đi lùa 2001		1.7	5.8	1	97,000	562,600
60	D1555A	Cánh ngang dưới bên ngoài cửa đi lùa 2001		1.7	5.8	1.243	97,000	699,312
61	D1551A	Khung bao ngang trên liền vách kính		1.7	5.8	2.164	97,000	1,217,466
61	D1544A	Cánh ngang trên cửa đi lùa 2001		1.7	5.8	0.99	97,000	556,974
62	D26144	Cánh ngang trên cửa đi lùa 71.5mm		2	5.8	1.115	97,000	627,299
63	D1548A	Trung gian 4 cánh cửa đi lùa 2001		1.7	5.8	0.62	97,000	348,812
64	C101	Nẹp kính đơn cho vách kính cửa đi, cửa sổ lùa 2001		0.9	5.8	0.133	97,000	74,826
65	D1779	Nẹp kính hộp cho vách kính cửa đi, cửa sổ lùa 2001		0.8	5.8	0.099	97,000	55,697
66	D1168	Thanh chuyển kính hộp lùa 93		2	5.8	0.399	97,000	224,477
67	D3211	Khung bao ngang trên cửa đi lùa 3 ray 2001		2	5.8	1.979	97,000	1,113,385
68	D3212	Khung bao ngang dưới cửa đi lùa 3 ray 2001 cao 55mm		2	5.8	2.297	97,000	1,292,292
69	D3213	Khung bao đứng cửa đi lùa 3 ray 2001		2	5.8	1.367	97,000	769,074
70	D9821	Khung bang ngang trên lùa 3 ray ( D1551)		2	5.8	2.86	99,000	1,642,212
71	D9828	Đồ cố định vách kính lùa 3 ray		2	5.8	2.002	99,000	1,149,548
72	D9829	Khung bao vách kính lùa 3 ray hệ 93		2	5.8	1.571	99,000	902,068
73	D9839	Nối vách kính		2	5.8	0.935	99,000	536,877
74	E192	Lá chóp		1.2	5.8	0.317	99,000	182,021
75	E1283	Khung sách		1.2	5.8	0.29	99,000	166,518

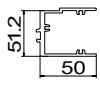
**CỬA ĐI XẾP TRƯỢT HỆ 63**

76	F605	Máng trượt cửa xếp trượt hệ 63		3	5.8	3.107	97,000	592,418
77	F606	Khung bao đứng		1.5	5.8	1.027	97,000	577,790
78	F607	Khung bao ngang dưới ray nổi		1.5	5.8	1.053	97,000	592,418
79	F2435	Ray âm dưới		1.5	5.8	1.351	97,000	760,073
80	C5409	Ray âm dưới		2	5.8	0.597	97,000	335,872
81	F523	Cánh cửa không lỗ vít		1.5	5.8	1.254	97,000	705,500
82	F520	Nẹp cánh cửa xếp trượt hệ 63		1	5.8	0.241	97,000	135,587
83	F521	Nẹp kính		1	5.8	0.222	97,000	124,897
84	F519	Ốp che nước mưa		1	5.8	0.177	97,000	99,580
85	F608	Pát liên kết máng treo F605 và đứng khung bao F606		2.5	5.8	1.44	97,000	810,144
86	F609	Pát liên kết rầy dẫn hướng F607 và đứng khung F606		0.5	5.8	1.377	97,000	774,700
87	F6029	Nẹp kính hộp		1.2	5.8	0.276	97,000	155,278
88	F417	Ke góc máng trượt		4	5.8	5.228	97,000	2,941,273