

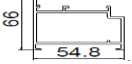

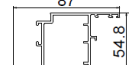



BẢNG BÁO GIÁ



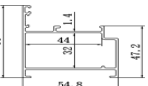

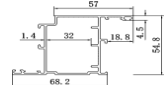
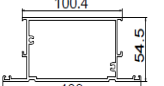
TP.HCM ngày 15 tháng 12 năm 2020

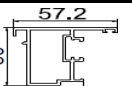
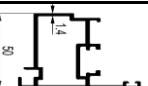
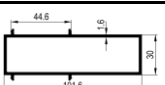
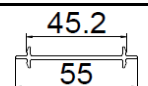
STT	MÃ HÀNG	TÊN GỌI	MẶT CẮT	ĐỘ DÀY	CHIỀU DÀI	(Kg/M)	ĐƠN GIÁ/KG	THÀNH TIỀN
CỬA ĐI XINGFA HỆ 55								
1	C3328	Khung bao cửa đi hệ 55		2	5.8	1.257	95,000	692,607
2	C3332	Cánh cửa đi mở trong hệ 55		2	5.8	1.442	95,000	794,542
3	C3303	Cánh cửa đi mở ngoài hệ 55		2	5.8	1.441	95,000	793,991
4	C44508	Khung bao cửa đi hệ 55 dày 1.4ly		1.4	5.8	0.927	95,000	510,777
5	C44512	Cánh cửa đi mở ngoài hệ 55 dày 1.4ly		1.4	5.8	1.132	95,000	623,732
6	C44522	Cánh cửa đi mở trong hệ 55 dày 1.4ly		1.4	5.8	1.132	95,000	623,732
7	C3304	Cánh cửa đi ngang dưới hệ 55		2	5.8	2.023	95,000	1,114,673
8	C3329	Nẹp gioăng lọc bụi cho cửa đi ngang dưới hệ 55		1.5	5.8	0.428	95,000	235,828
9	C22900	Nẹp gioăng lọc bụi cho cửa đi ngang dưới hệ 55 có gờ		1.5	5.8	0.476	95,000	262,276
10	C3319	Ngưỡng cửa , cửa đi hệ 55		1.6	5.8	0.689	95,000	379,639
11	C3323	Đồ động cửa đi 2 cánh hệ 55		1.8	5.8	1.086	95,000	598,386
12	C22903	Đồ động cửa đi/ Sổ 2 cánh hệ 55		1.4	5.8	0.891	95,000	490,941
13	C3310	Nối khung cho vách kính lớn hệ 55		1.6	5.8	1.308	95,000	720,708
14	C3300	Nối khung cho vách kính, cửa hệ 55		2	5.8	0.347	95,000	191,197

15	C3209	Khung bao cho vách kính		1.4	5.8	0.802	95,000	441,902
16	C459	Thanh truyền khóa cửa đi, cửa sổ hệ 55		2.5	5.8	0.139	95,000	76,589
17	C3326	Nối khung 90 độ hệ 55		2.2	5.8	1.275	95,000	702,525
18	F077	Pano có rãnh cửa đi hệ 55		1	5.8	0.664	99,000	381,269
19	C3295	Nẹp kính vuông cho kính 5-10mm hệ 55		1	5.8	0.271	95,000	149,321
20	C3206	Nẹp kính bầu cho kính 5 -10 mm hệ 55		1	5.8	0.257	95,000	141,607
21	C3236	Nẹp kính hộp cho kính 16 -19 mm hệ 55		1	5.8	0.227	95,000	125,077

CỬA SỔ XINGFA HỆ 55 DÀY

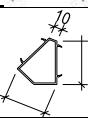

22	C3209	Khung bao cho vách kính		1.4	5.8	0.802	95,000	441,902
23	C3318	Khung bao cửa sổ hệ 55		1.4	5.8	0.876	95,000	482,676
24	C3208	Khung bao chuyển hướng		1.4	5.8	0.76	95,000	418,760
25	C3202	Cánh cửa sổ mở quay ngoài		1.4	5.8	1.088	95,000	599,488
26	C8092	Cánh cửa sổ mở quay ngoài ke nhảy		1.4	5.8	1.064	95,000	586,264
27	C3033	Đồ động cửa sổ mở quay 2 cánh		1.4	5.8	0.825	95,000	454,575
28	C3313	Đồ cố định chữ T tách khung		1.4	5.8	1.01	95,000	556,510
29	C3203	Đồ cố định chữ T có lỗ vít		1.4	5.8	0.95	95,000	523,450
30	C459	Thanh truyền khóa cửa đi, cửa sổ hệ 55		2.5	5.8	0.139	95,000	76,589
31	C3295	Nẹp kính vuông cho kính 5-10mm hệ 55		1	5.8	0.271	95,000	149,321
32	C3296	Nẹp kính cho C3328, C3318, C3313 kính 5-10mm hệ 55		1	5.8	0.237	95,000	130,587

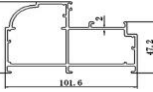
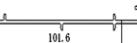
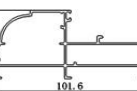
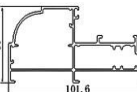
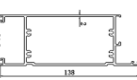

33	C3206	Nẹp kính bầu cho kính 5 -10 mm hệ 55		1	5.8	0.275	95,000	151,525
34	C3236	Nẹp kính hộp cho kính 16 - 19 mm hệ 55		1	5.8	0.227	95,000	125,077
35	C3336	Nẹp kính hộp cho kính 8-10 mm hệ 55		1	5.8	0.229	95,000	126,179
36	C910	Nối góc 135		1.8	5.8	0.916	95,000	504,716

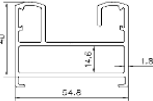
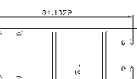
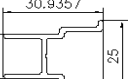
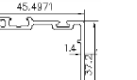

CỬA MỞ QUAY HỆ 55 BẢN 100

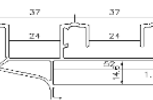

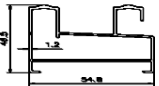
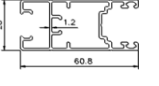
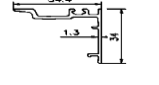
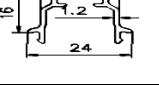
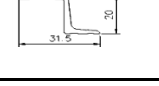
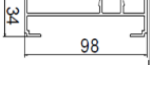
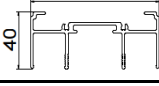
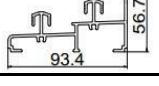
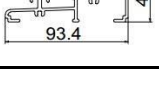
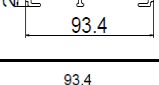
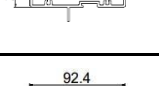
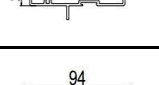
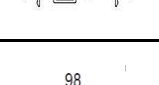

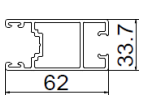
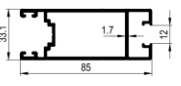
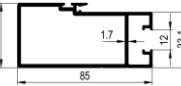
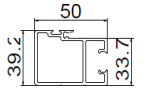
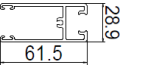
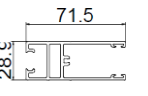
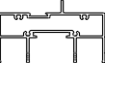
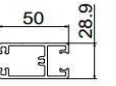
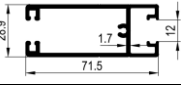
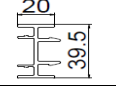
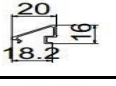

37	C38019	Khung bao cửa đi mở quay hệ 100		2	5.8	2.057	96,000	1,145,338
38	C38010	Thanh ghép khung hệ mở quay 100		2	5.8	0.617	96,000	343,546
39	C38039	Khung bao vách kính hệ 100		1.4	5.8	1.375	96,000	765,600
40	C38038	Khung bao cửa sổ mở quay hệ 100		1.4	5.8	1.421	96,000	791,213
41	C38032	Thanh ngang dưới cửa đi mở quay hệ 55		2	5.8	2.26	95,000	1,245,260

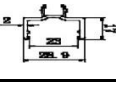
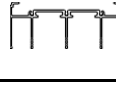
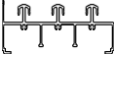
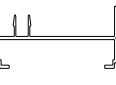
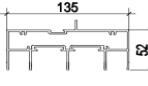
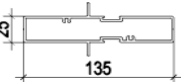
CỬA LÙA ĐI 55

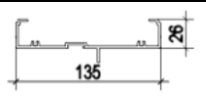
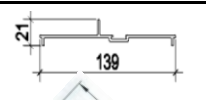
42	D47713	Khung bao lùa đi 55		1.8	5.8	1.223	96,000	680,966
43	D45316	Cánh lùa đi hệ 55		1.8	5.8	1.319	96,000	734,419
44	D46070	Ốp khóa trung gian cửa đi lùa 55		1.5	5.8	0.364	96,000	202,675
45	D45478	Ốp cánh cửa đi lùa 55		1.4	5.8	0.383	96,000	213,254
46	D45318	Trung gian cửa đi lùa 55		1.8	5.8	0.566	96,000	315,149
47	D45482	Khung cửa sổ lùa 3 ray hệ 55		1.4	5.8	1.467	96,000	816,826

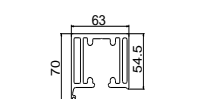
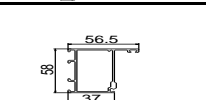
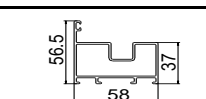
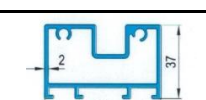
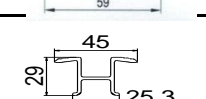
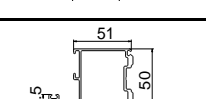
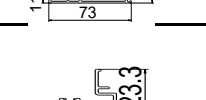
XINGFA HỆ LÙA 55									
48	D23151	Khung bao cửa lùa hệ 55		1.4	5.8	0.949	95,000	522,899	
49	D23156	Cánh cửa lùa hệ 55		1.4	5.8	0.936	95,000	515,736	
50	D23157	Ốp góc cho cánh cửa lùa hệ 55		1.4	5.8	0.365	95,000	201,115	
51	D23158	Trung gian 4 cánh cửa lùa hệ 55		1.4	5.8	0.229	95,000	126,179	
52	D23159	Thanh chắn nước mưa cửa lùa hệ 55		1.4	5.8	0.279	95,000	153,729	
CỬA ĐI MỞ TRƯỢT XINGFA HỆ 2001/93									
53	D1543A	Khung bao đứng cửa đi lùa 2001		1.8	5.8	1.134	95,000	624,834	
54	D1541A	Khung bao ngang trên cửa đi lùa 2001		1.8	5.8	1.459	95,000	803,909	
54	D1542A	Khung bao ngang dưới cửa đi lùa 2001 cao 57mm		1.8	5.8	1.706	95,000	940,006	
55	D1942	Khung bao ngang dưới cửa đi lùa 2001 cao 40mm		2	5.8	1.561	95,000	860,111	
55	D17182	Khung bao ngang dưới cửa đi lùa 2001 cao 25mm		2	5.8	1.307	95,000	720,157	
56	D1559A	Khung bao ngang cho vách kính cửa đi lùa 2001		1.7	5.8	1.07	95,000	589,570	
56	D2618	Đồ trung gian cho vách kính cửa đi lùa 2001		2	5.8	1.546	95,000	851,846	
57	D1578	Nối khung cho vách kính cửa đi lùa 2001		2	5.8	0.676	95,000	372,476	
57	D1549A	Nối khung bao cho vách kính cửa đi lùa 2001		1.7	5.8	0.712	95,000	392,312	

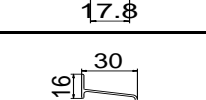
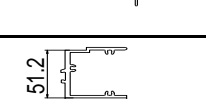
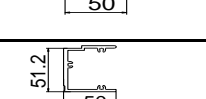
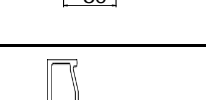
58	D1546A	Cánh đứng bên cửa đi lùa 2001		1.7	5.8	1.273	95,000	701,423
58	D26146	Cánh đứng bên cửa đi lùa 85mm		2	5.8	1.33	95,000	732,830
59	D28127	Cánh đứng móc cửa đi lùa 85mm		2	5.8	1.303	95,000	717,953
59	D1547A	Cánh đứng móc cửa đi lùa 2001		1.7	5.8	1.098	95,000	604,998
60	D1545A	Cánh ngang dưới bên trong cửa đi lùa 2001		1.7	5.8	1	95,000	551,000
60	D1555A	Cánh ngang dưới bên ngoài cửa đi lùa 2001		1.7	5.8	1.243	95,000	684,893
61	D1551A	Khung bao ngang trên liền vách kính		1.7	5.8	2.164	95,000	1,192,364
61	D1544A	Cánh ngang trên cửa đi lùa 2001		1.7	5.8	0.99	95,000	545,490
62	D26144	Cánh ngang trên cửa đi lùa 71.5mm		2	5.8	1.115	95,000	614,365
63	D1548A	Trung gian 4 cánh cửa đi lùa 2001		1.7	5.8	0.62	95,000	341,620
64	C101	Nẹp kính đơn cho vách kính cửa đi, cửa sổ lùa 2001		0.9	5.8	0.133	95,000	73,283
65	D1779	Nẹp kính hộp cho vách kính cửa đi, cửa sổ lùa 2001		0.8	5.8	0.099	95,000	54,549
66	D34608	Thanh chuyển kính hộp lùa 93		2	5.8	0.399	95,000	219,849
67	D3211	Khung bao ngang trên cửa đi lùa 3 ray 2001		2	5.8	1.959	95,000	1,079,409
68	D3212	Khung bao ngang dưới cửa đi lùa 3 ray 2001 cao 55mm		2	5.8	2.295	95,000	1,264,545
69	D3213	Khung bao đứng cửa đi lùa 3 ray 2001		2	5.8	1.367	95,000	753,217
70	D9821	Khung bang ngang trên lùa 3 ray (D1551)		2	5.8	2.86	99,000	1,642,212
71	D9828	Đồ cố định vách kính lùa 3 ray (D2618)		2	5.8	2.002	99,000	1,149,548

72	D9829	Khung bao vách kính lùa 3 ray hệ 93		2	5.8	1.571	99,000	902,068
73	D9839	Nối vách kính		2	5.8	0.935	99,000	536,877
74	E192	Lá chớp		1.2	5.8	0.317	99,000	182,021
75	E1283	Khung sách		1.2	5.8	0.29	99,000	166,518
CỬA ĐI XẾP TRƯỢT HỆ 63								
76	F605	Máng trượt cửa xếp trượt hệ 63		3	5.8	3.107	95,000	1,711,957
77	F606	Khung bao đứng		1.5	5.8	1.027	95,000	565,877
78	F607	Khung bao ngang dưới ray nổi		1.5	5.8	1.053	95,000	580,203
79	F2435	Ray âm dưới		1.5	5.8	1.351	95,000	744,401
80	C5409	Ray âm dưới		2	5.8	0.595	95,000	327,845
81	F523	Cánh cửa không lỗ vít		1.5	5.8	1.254	95,000	690,954
82	F520	Nẹp cánh cửa xếp trượt hệ 63		1	5.8	0.241	95,000	132,791
83	F521	Nẹp kính		1	5.8	0.222	95,000	122,322
84	F519	Ốp che nước mưa		1	5.8	0.177	95,000	97,527
85	F608	Pát liên kết máng treo F605 và đứng khung bao F606		2.5	5.8	1.44	95,000	793,440
86	F609	Pát liên kết rầy dẫn hướng F607 và đứng khung F606		0.5	5.8	1.377	95,000	758,727
87	F6029	Nẹp kính hộp		1.2	5.8	0.276	95,000	152,076
88	F417	Ke góc máng trượt		4	5.8	5.228	95,000	2,880,628